

first flush™ POST/WALL WATER DIVERTER

Product: Post/Wall Mounted Water Diverter 300mm
Code: WDPW01

Product: 300mm Galvanised Steel Stand
Code: WDAC01

Product: 300mm PVC Pipe
Code: WDAC09

Prevents the first flush of rainwater, which may contain contaminants from the roof, from entering the tank.



Product Description

A versatile unit that can be mounted on a wall, post or stand, to hold larger volumes of water. It can be adapted to suit a wide range of applications and will manage single or multiple pipes coming from the roof to divert between 20 and 150L.

The kit is easy to freight, and the diverter volume can be made on site to match exact requirements – just add the appropriate length of 300mm pipe. The kit includes a saddle and a galvanised steel wall mounting bracket. A galvanised steel stand is an optional alternative to post or wall mounting.

Features and Benefits

- Prevents sediment, bird droppings, spiders, insects, mosquito eggs and debris from entering the rainwater tank.
- Improves water quality, protects pumps and internal appliances.
- Ideal to use in conjunction with a rain head.
- Easy installation, just add 300mm pipe length and glue.
- 300mm pipe can be purchased from Rain Harvesting.
- No mechanical parts.
- Inlet fits 90mm pipe or 100mm female fitting.

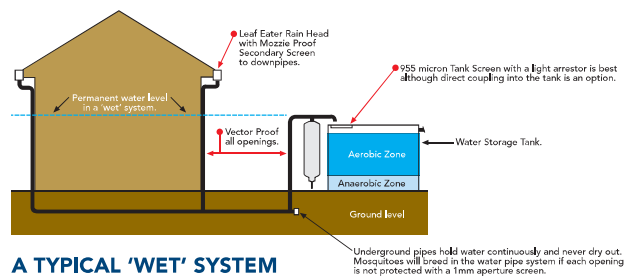

A TYPICAL 'WET' SYSTEM

A 'wet' system is a system where the pipes are fitted in such a way that when the rain stops the pipes do not drain out. They hold water. With this type of system, the pipes must be fitted with screens at each end to ensure that vectors (mosquitoes etc.) cannot enter and breed within the system.

A 'wet' system needs to be fitted with a First Flush Water Diverter at the tank with a capacity equal to that of the water held in the 'wet' pipe system PLUS whatever amount is required to be diverted from the roof.

To lessen the amount of water to be diverted at the tank, Downpipe First Flush Water Diverters can be fitted on the building to take the required first flush from the roof.

Compliance

- AS/NZS 4020:2005 – Testing of products for use in contact with drinking water.

Installation

Determine the length of pipe required using the table opposite.

Inlet End: The ball seat #6 is inserted into the top of the end cap as shown.

For 90mm infeed – insert the ball seat #6 and attach the infeed pipe hard down on top of ball seat #6.

For 100mm infeed – insert the ball seat #6 and glue the 90mm keeper ring (28mm long) hard down on top of the ball seat #6 to keep it firmly in place.

Outlet End: The outlet requires only 90mm pipe. Assemble as shown making sure to insert ball #7 before attaching cap #12. Select one of the four control valves #13 and fit into hose connector #14. Save the remaining valves for possible later use.

CAUTION: When placing the unit into the wall/post bracket #10, support the unit so that it can not fall forward then fit the pipe bracket #4. FAILURE TO SUPPORT THE UNIT IN THE UPRIGHT POSITION COULD CRACK THE BOTTOM CHAMBER CAP.

Stands: It is important to line up the center of the chamber outlet with the weld on the stand. Make sure that the stand is bolted down securely and that the pipe work connected to the top of the diverter chamber is appropriately secured so that the diverter is stable and the unit is not stressed by bad alignment.

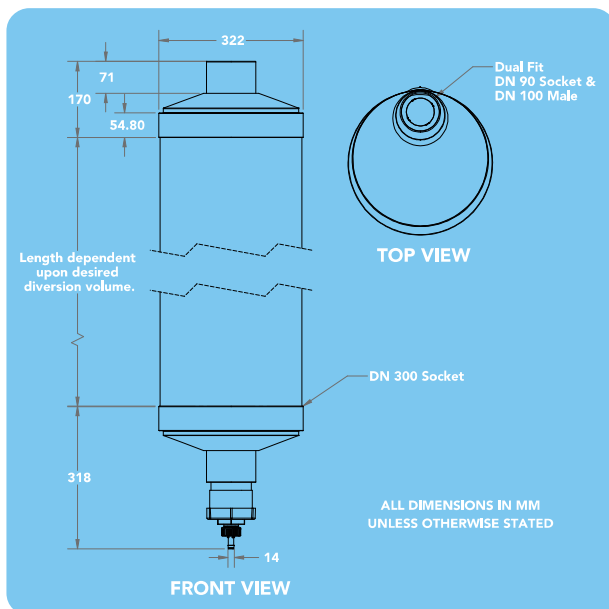

SIZES		PIPE	TOTAL
Litres	Length (mm)	Total Height Required (mm)	
20	225	590	
30	365	730	
40	500	865	
50	630	995	
60	780	1145	
70	905	1270	
80	1050	1415	
90	1180	1545	
100	1310	1675	
120	1610	1975	
130	1735	2100	
150	2005	2370	

REFERENCE CHART					
1	In-feed from the roof	6	Ball seat	11	Chamber Outlet
2	Tee Junction	7	Sealing Ball	12	Screw Cap with O'Ring Seal
3	To the tank	8	Diverter Chamber	13	Flow Control Valve
4	Pipe Bracket	9	Filter Screen	14	Hose Connection
5	Chamber Inlet	10	Wall/Post Bracket	15	Optional Stand

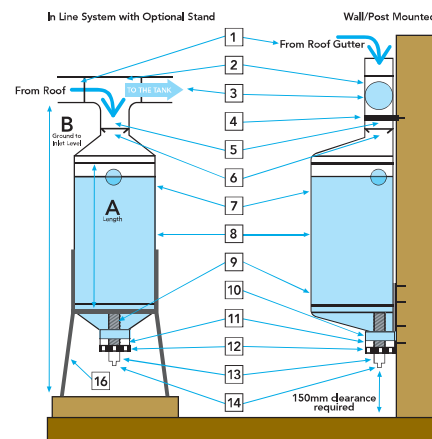

The following factors can be used as a guide to determining the volume of water to be diverted.

POLLUTION FACTOR FOR THE ROOF

Minimal Pollution – divert 0.5L per m2

Open field, no trees, no bird droppings, clean environment.

Substantial Pollution – divert 2L per m2

Leaves and debris, bird droppings, various animal matter, e.g. dead insects, skins etc.

The above quantum are the results of preliminary testing. Individual site analysis and field testing is required to more accurately assess the quantum to be diverted in each individual case.

DIVERSION FACTOR FOR A FIRST FLUSH WATER DIVERTER

m2 Roof Area X Pollution Factor = Litres to be diverted.

Example for a minimal polluted roof of 100m2

100 X 0.5 = 50 Litres to be diverted.

Example for a heavily polluted roof of 100m2

100 X 2 = 200 Litres to be diverted.

Maintenance

Ensure the outlet of the diverter is clear of any debris. If the outlet is blocked, the chamber will not empty and the first flush of water when it rains will not be diverted.

Periodically unscrew the End Cap of the water diverter to allow debris to fall out. Hose or wash the Filter Screen if required and clean the Flow Control Valve.