



# Partfill

20 L / MIN

### Description

RoJo Part Fill is a low flow valve intended for use in rain water harvesting tanks. The purpose of the float valve is to automatically maintain a low level of water in the tank during periods of no or low rainfall. This allows services fed by the tank to continue while leaving capacity in the tank for refilling by the next rain.

### Applications

Maintaining water levels in:

- Rain water harvesting tanks
- Water cisterns
- Irrigation and process applications.

### Flow Graph

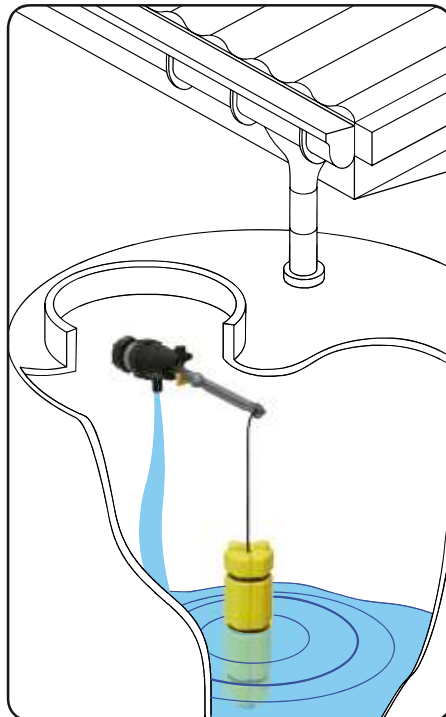
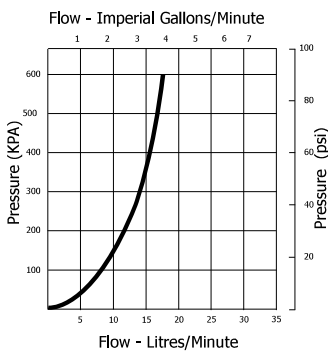

### Outline of Operation

- The valve is installed through the side wall of a storage tank. It should be mounted above the overflow level of the tank to prevent backflow.
- As the tank empties the weighted float travels down the cord and sits on the bottom stop to activate the valve.
- The valve will run until the weighted float lifts clear of the bottom stop.
- The float will then rise as rainwater fills the tank and falls as the tank water is used.
- The valve will only function at times when rain fall is insufficient to maintain a water level in the tank above the bottom stop.
- The use of a flow restrictor before the valve will not cause the valve to malfunction.

### Features

- Ideal for use with all makes and models of rain water harvesting tanks
- Compatible with trickle flow restrictors
- Compact
- Constructed from non corroding materials
- Built in non return valve
- Valve can be locked in off position using the lock off switch

### Available Inlet Sizes

15mm (1/2")  
20mm (3/4")

All supplied with long tail thread with back nut.

### Pressure Range

0 – 10 Bar (0 -150 psi)

### Typical Installation

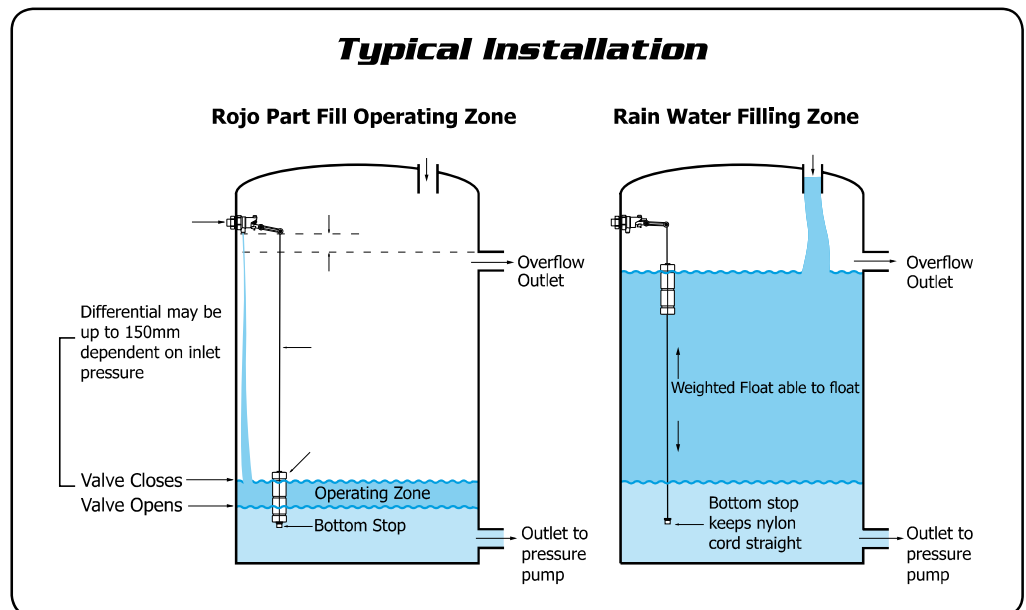

Note: Keep overflow, rain water inlet and outlet to pressure pump as far away from the float valve as possible.

# ROJO PARTFILL

## DIMENSIONS & MATERIALS



# Partfill

20 L / MIN

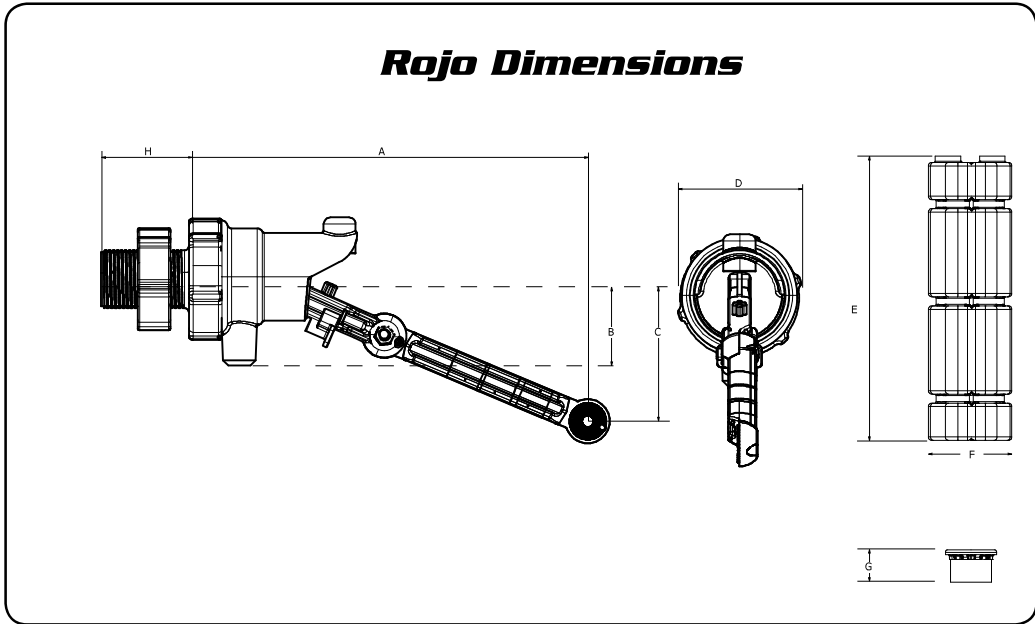

<b>Rojo Dimensions</b>		
	mm	inches
A	210	8 1/4
B	40	1 9/16
C	59	2 5/16
D	56	2 3/16
E	208	8 3/16
F	62	2 7/16
G	20	12/16
H	38	1 1/2

<b>Materials</b>	
Valve Body Tail & Nut	ABS
Arm Extension Arms Internal Grey Mouldings	Glass Filled Nylon
Yellow Valve Parts Filter	Acetal
Float	HDPE
Springs Bolts Nuts	304 Stainless Steel
O' Rings	Nitrile
Float Cord	Polyester

Maximum Temperature of Operation 45°C, 115°F

# ROJO PARTFILL

## PARTS IDENTIFICATION SHEET



# Partfill

20 L / MIN



CODE	DESCRIPTION
1 RJPP1	Float Assembly
2 RJPP2	Body Assembly
3 RJPP3	Inner Cartridge Assy (PF)
4 RJP415	15mm (1/2") Tail Assy
RJP420	20mm (3/4") Tail Assy
RJP420E	20mm (3/4") Ezi Start Tail Assy

CODE	DESCRIPTION
1 RJPP1010	Bottom Stop (PF)
2 RJPP1020	Weighted Float (PF)
3 RJPP1030	Cord (PF)
4 RJPP1040	Rojo Part Fill Long Arm

CODE	DESCRIPTION
1 RJP2010	Lock-Off Switch
2 RJP2030	Body
3 RJPP2041	Arm Assy Grey
4 RJPP2051	Retainer Grey

CODE	DESCRIPTION
1 RJPP3011	Inner Cartridge Part Fill
2 RJP3020	Filter

CODE	DESCRIPTION
1 RJP4010	15mm (1/2") Tail
RJP4011	20mm (3/4") Tail
RJP4012	20mm (3/4") Tail Ezi Start
2 RJP4020	15mm Seal Washer
RJP4021	20mm Seal Washer
3 RJP4030	15mm (1/2") Backing Nut
RJP4131	20mm (3/4") Backing Nut