



DN 125 / 200

3P Attenuation and Infiltration Filter XL for concrete manhole DN 125 / 150 / 200

DN 125 / 200 Item No. 1000685
 DN 150 Item No. 1000689
 Price 672.00 €

Straightforward rainwater filter with integrated dirt retention basket for installation before a shaft. The dirt basket made of plastics can be removed easily with the removal handle. The 3P Infiltration and Retention Filter XL is suitable for flushing the toilet, washing machine and for watering the garden and where the rainwater has to be infiltrated. The two upper adapters DN 125 or DN 200 can be used as inlets or also optionally as an emergency overflow. The lower or lateral adapter is used as inlet to the rainwater tank. There you can also install a calmed inlet.



DN 150

Connections: DN 125 / DN 150 / DN 200

Connection capacity: for roof areas up to 387 m² / 627 m² / 1347 m²

The cleaned water can be used for toilet flushing, washing machine and for garden watering.

The filter has to be cleaned depending on the contamination several times during the year.

Material filter basket: Stainless steel

Ø 410 x 275 mm

Mesh size: 0.55 mm

Diameter: 785 mm

Height: 660 mm



Filter Shaft DN 1000 for 3P Attenuation and Infiltration Filter XL for concrete manhole

Assembly model

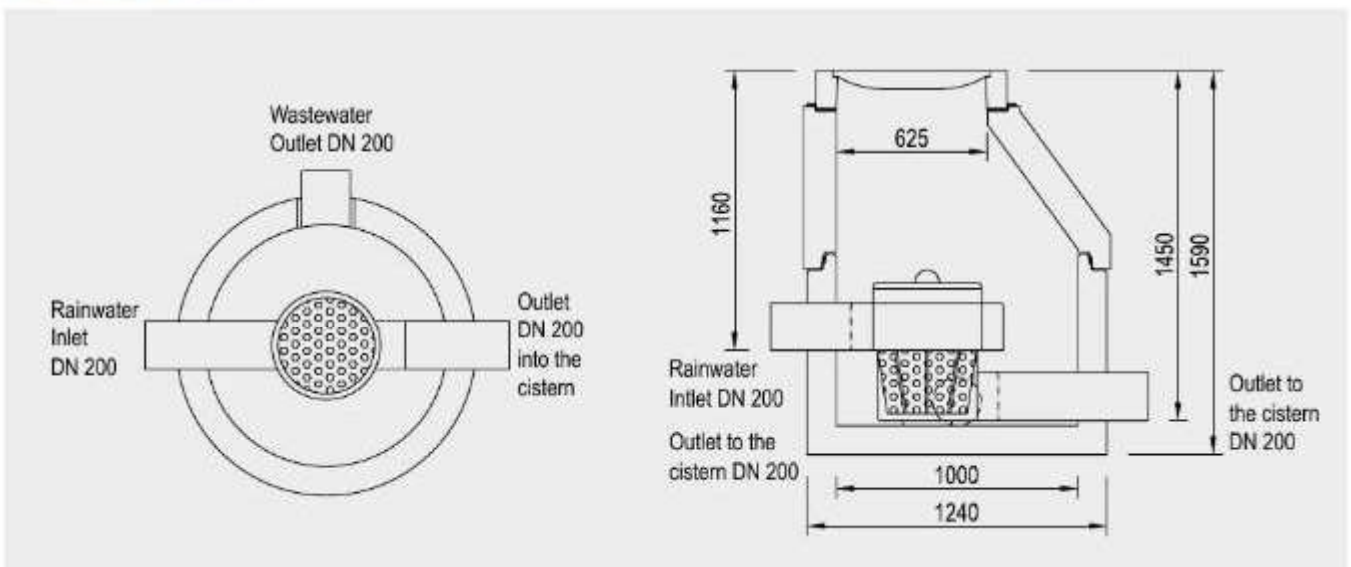

3P Special Set RF XL for concrete manhole

DN 125 / 200 Item No. 1000688
 DN 150 Item No. 1000691

- Attenuation and Infiltration Filter XL for concrete manhole
- 3P Overflow Siphon DN 150 / 200 / 250
- 3P Calmed Inlet DN 150 / 200 / 250

instead of ~~1.137,-~~
1.014,-